

REVISIONS				
ZONE	REV	DESCRIPTION	DATE	APPROVED

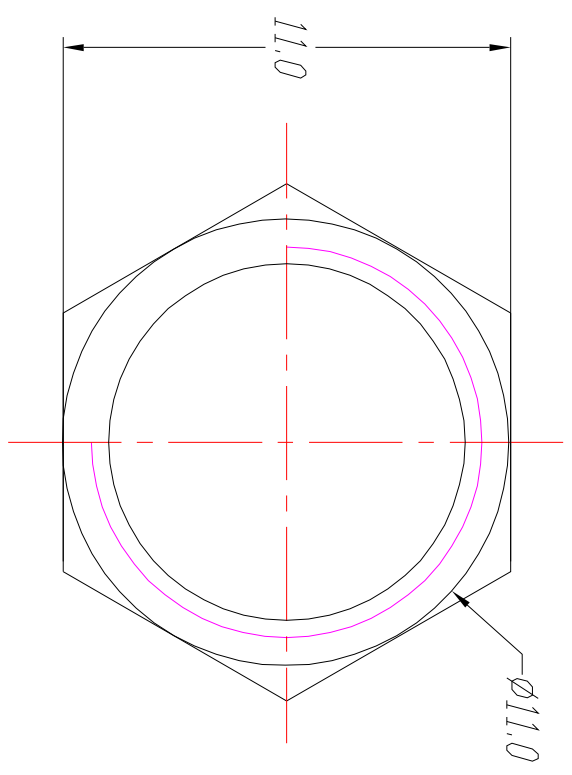
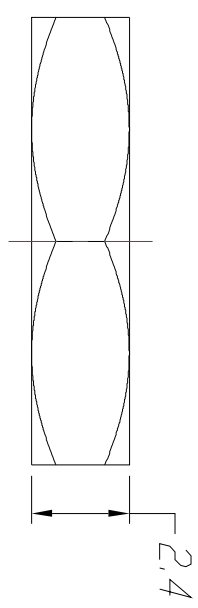
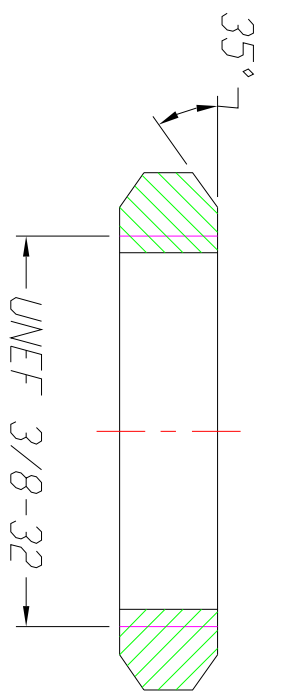

- NOTES:**
1. MAT'L: BRASS PER ASTM B16(QQ-B-626, ALLOY 360, 1/2H)
  2. REMOVE ALL BURRS AND BREAK SHARP EDGES .005MAX
  3. SURFACE FINISH TO BE 63 OR SMOOTHER
  4. FINISH: NICKEL PLATE PER QQ-N-290, CLASS 1, GRADE G

		SIGNATURE		DATE		P/N: N-001	
FIRST ANGLE PROJECTION		HEHABIN		2005/6/17		TITLE	
UNLESS OTHERWISE SPECIFIED		CHECKED		FENGCIYU		2005/6/17	
DIMENSIONS ARE IN: MM		DESIGN ENGR.					
TOLERANCE ARE		DESIGN					
LINEAR: ±0.1		MANUF ENGR.					
ANGULAR: ±2°		QUALITY ENGR.					
		SCALE		NONE			
		SIZE		FSCM NO		DWGNO	
		B				TL-P002	
						REV.	
						SHEET 1 OF 1	