

# CTP-BR-1001-H-B

# CTP-7BR-1001-H-B

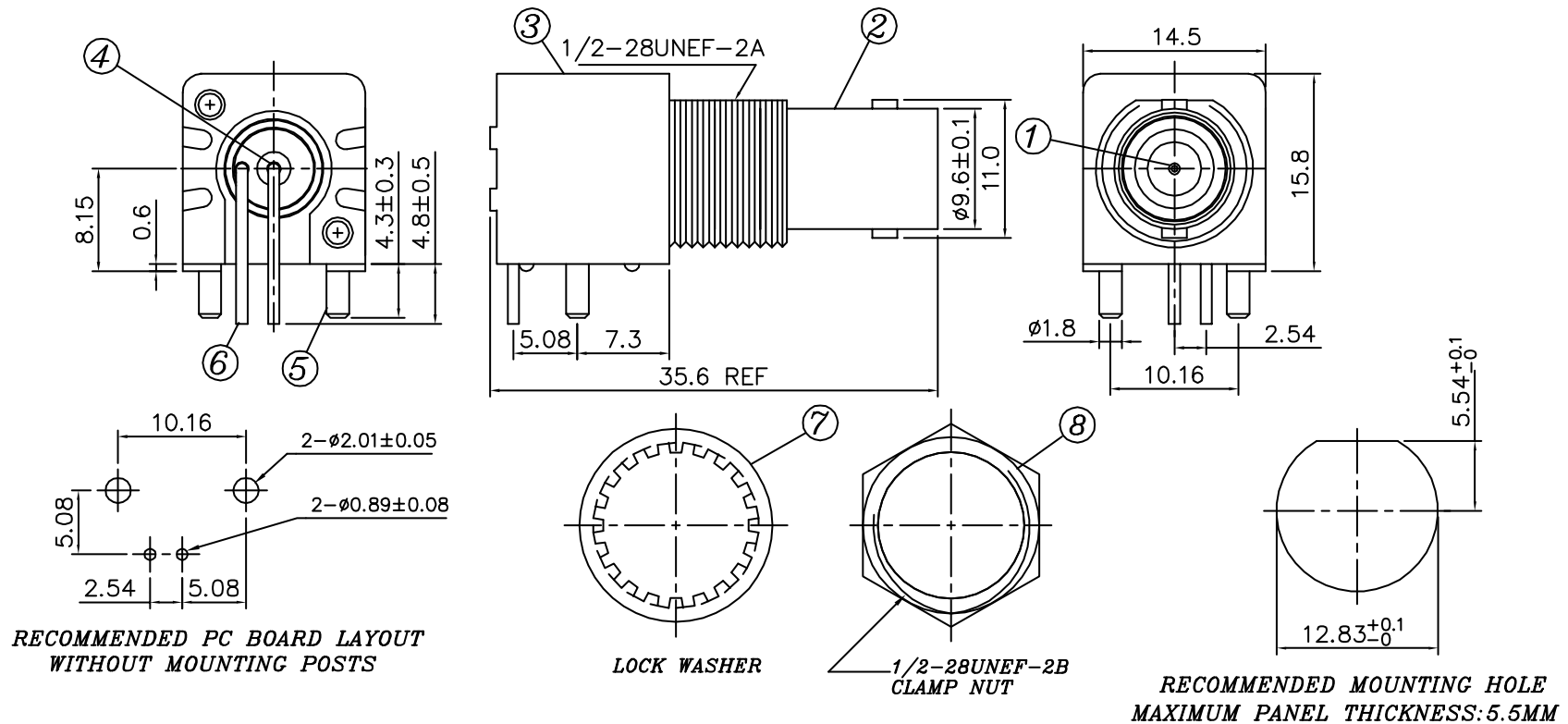

## MATERIAL & FINISH

① CENTER CONTACT	: BRONZE GOLD PLATING
② BODY	: ZINC ALLOY NICKEL PLATING
③ HOUSING	: PBT (94 V-0) BLACK
④ INSULATOR	: PE-606
⑤ MOUNTING POST	: BRONZE, TIN PLATING
⑥ SOLDER TAIL	: COPPER WIRE, TIN PLATING
⑦ WASHER	: STEEL, NICKEL PLATING
⑧ NUT	: BRASS, NICKEL PLATING



Phone 1-800-809-2751

Fax 1-510-440-0579

www.connect-tech-products.com • info@connect-tech-products.com

4428 Technology Drive • Fremont, CA 94538, USA • 510-498-8815 • Fax: 510-440-0579