

CTP-TR-1001-L-Z 50 OHM

CTP-7TR-1001-L-Z 75 OHM

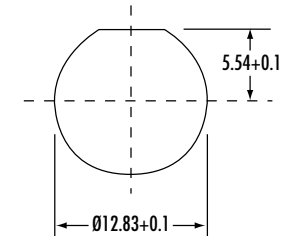
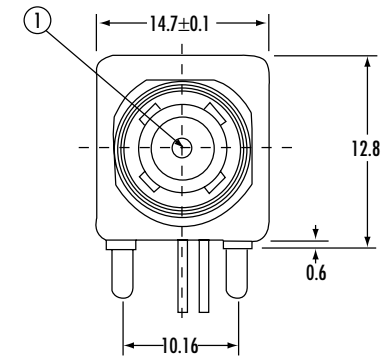
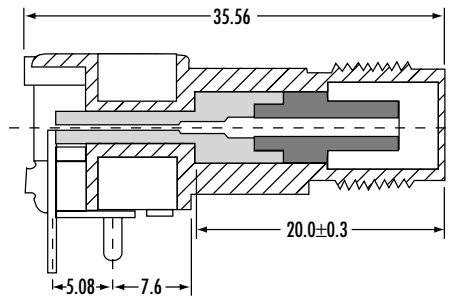
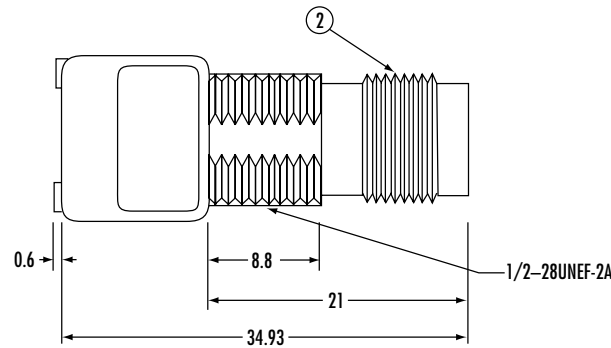
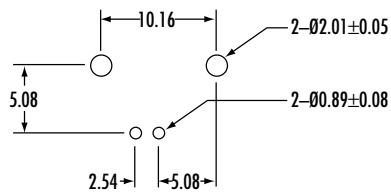
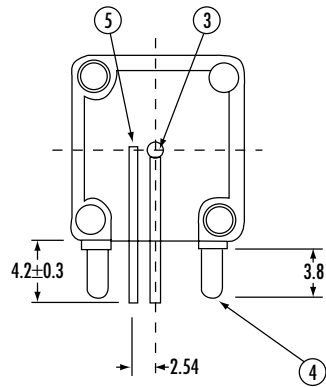

RIGHT ANGLE DIE-CAST TNC JACK

MATERIALS:

1. CENTER CONTACT: PHOSPHOR BRONZE, GOLD PLATING
2. BODY: DIECAST (ZINC #3), NICKEL PLATING
3. INSULATOR: PE-606
4. MOUNTING POST: BRASS, TIN LEAD PLATING
5. GROUND TAIL: BRASS WIRE, TIN LEAD PLATING
6. WASHER: PHOSPHOR BRONZE, NICKEL PLATING
7. NUT: BRASS, NICKEL PLATING

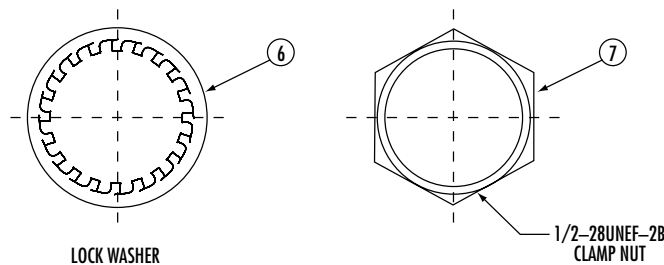

1. IMPEDANCE: 75 OHM
2. VOLTAGE RATING: 500V RMS
3. FREQUENCY RANGE: 0~4 GHZ
4. INTERFACE PER MIL-C: 39012C

Phone 1-800-809-2751



Fax 1-510-440-0579

www.connect-tech-products.com • info@connect-tech-products.com

4428 Technology Drive • Fremont, CA 94538, USA • 510-498-8815 • Fax: 510-440-0579