

CTP-TV-1001-L-Z

50 OHM TNC JACK

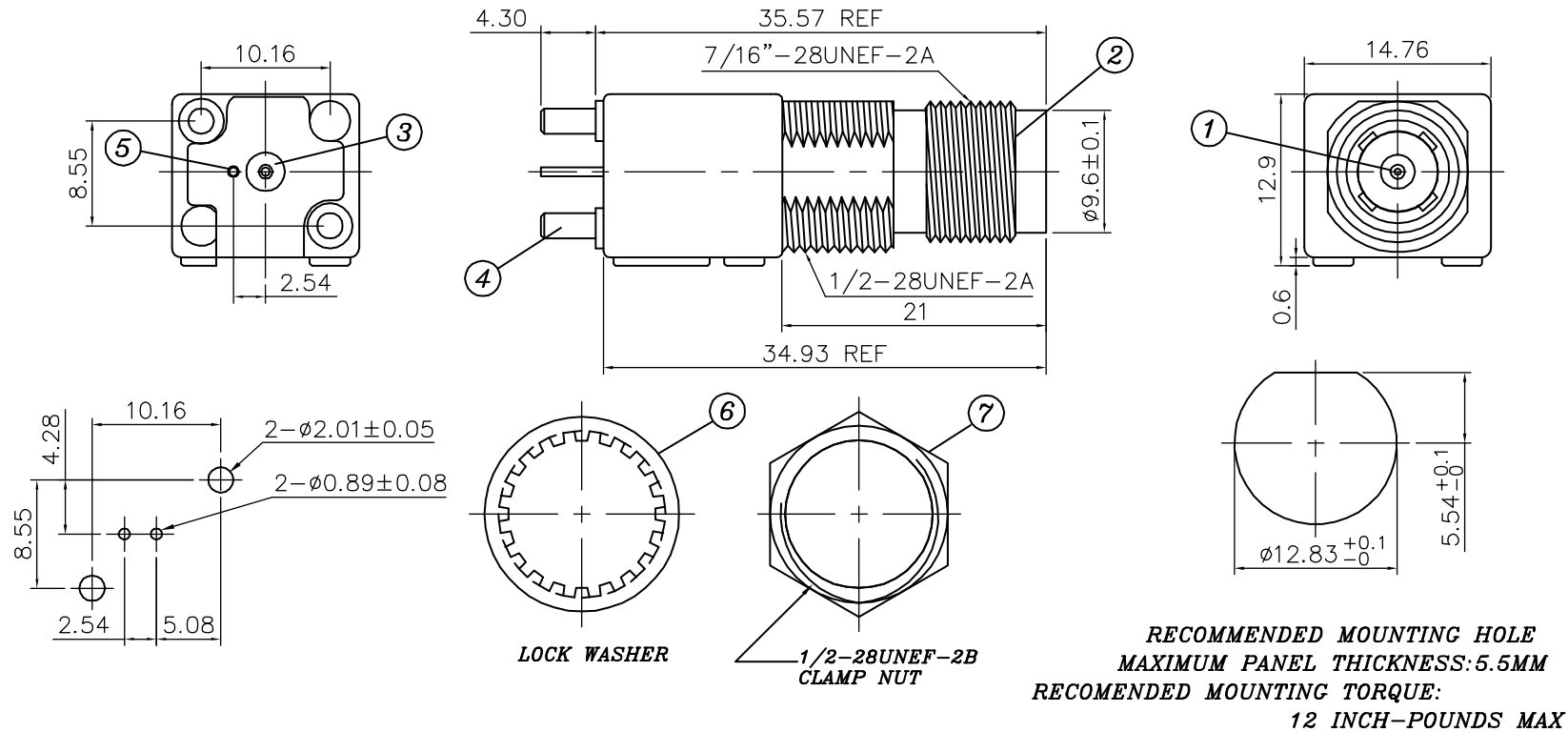

MATERIAL & FINISH

- ① CENTER CONTACT : PHOSPHOR BRONZE, GOLD PLATING
- ② BODY : DIECAST (ZINC #3) NICKEL PLATING
- ③ INSULATOR : PE-606
- ④ MOUNTING POST : BRASS, TIN PLATING
- ⑤ SOLDER TAIL : BRASS WIRE, TIN PLATING
- ⑥ WASHER : PHOSPHOR BRONZE, NICKEL PLATING
- ⑦ NUT : BRASS, NICKEL PLATING

Note:
 Tolerances:
 X. ± 0.5
 X.X ± 0.3
 X.XX ± 0.2



Phone 1-800-809-2751

Fax 1-510-440-0579

www.connect-tech-products.com • info@connect-tech-products.com

4428 Technology Drive • Fremont, CA 94538, USA • 510-498-8815 • Fax: 510-440-0579