

CTP-TR-1001-L-Z

REV. B

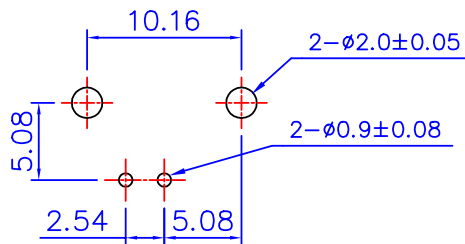

RECOMMENDED PC BOARD LAYOUT
WITHOUT MOUNTING POSTS

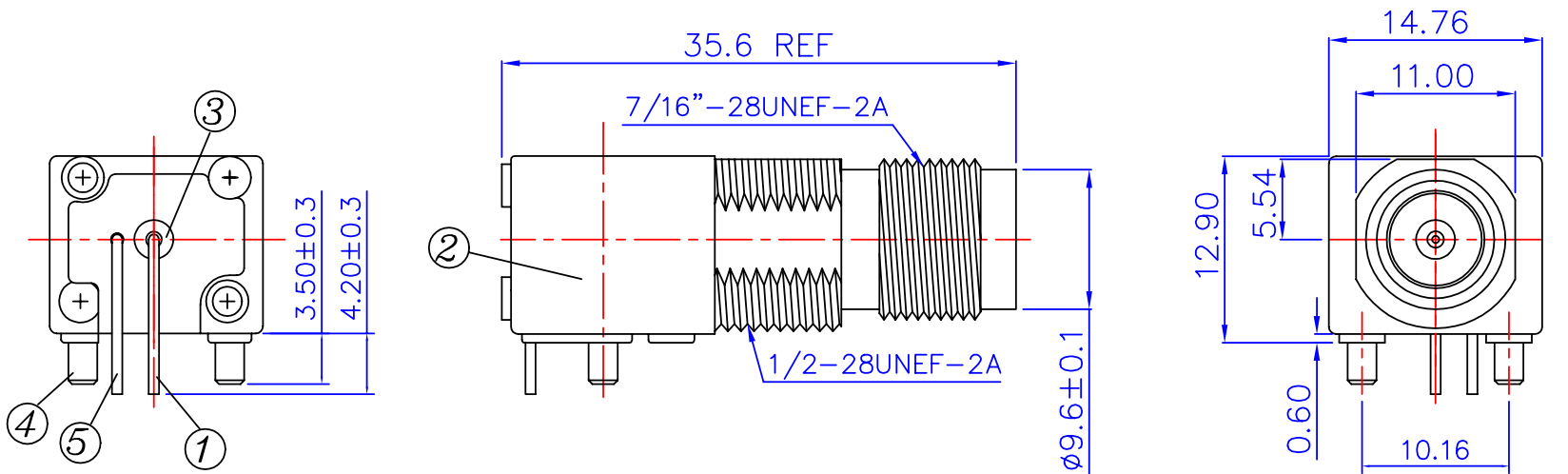
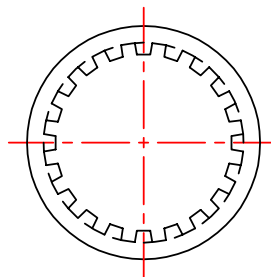

⑥ LOCK WASHER

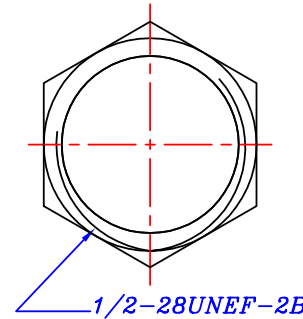

⑦ CLAMP NUT

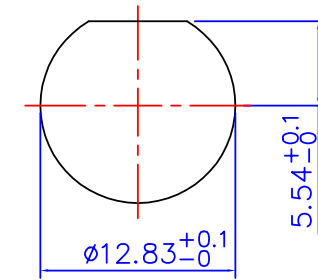

RECOMMENDED MOUNTING HOLE
MAXIMUM PANEL THICKNESS: 5.5MM

MATERIAL & FINISH

- ① CENTER CONTACT : PHOSPHOR BRONZE, GOLD PLATING
- ② BODY : ZINC ALLOY NICKEL PLATING
- ③ INSULATOR : PE-606
- ④ MOUNTING POST : BRASS, TIN PLATING
- ⑤ SOLDER TAIL : COPPER WIRE, TIN PLATING
- ⑥ WASHER : STEEL, NICKEL PLATING
- ⑦ NUT : BRASS, NICKEL PLATING

UNLESS OTHERWISE SPECIFIED:
DIMENSIONS ARE IN mm
TOLERANCES ARE:
X. ± 0.5
X.X ± 0.3
X.XX ± 0.2
ANGLES ± 3 DEG



Phone 1-800-809-2751

Fax 1-510-440-0579

www.connect-tech-products.com • info@connect-tech-products.com

4428 Technology Drive • Fremont, CA 94538, USA • 510-498-8815 • Fax: 510-440-0579