

CTP-BR-1003-L-W

CTP-7BR-1003-L-W

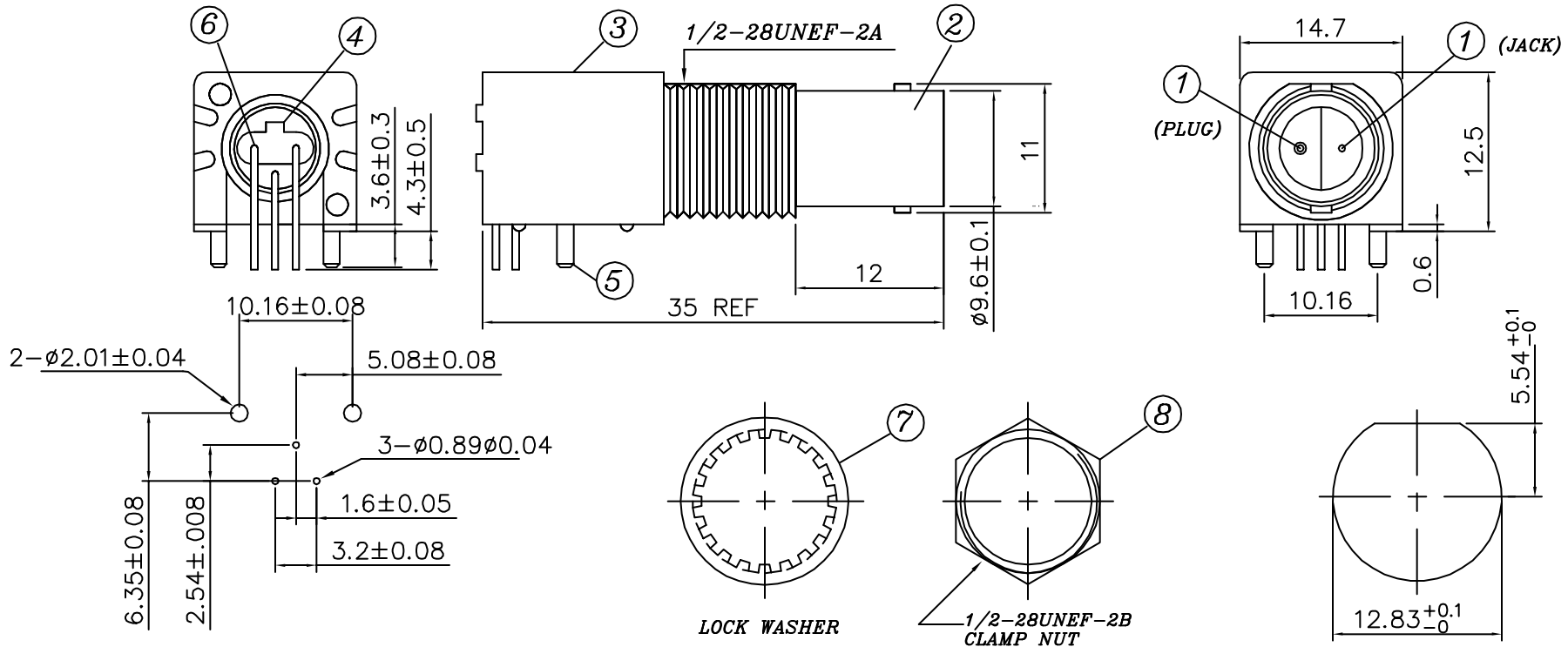

RECOMMENDED PC BOARD LAYOUT
WITHOUT MOUNTING POSTS

RECOMMENDED MOUNTING HOLE
MAXIMUM PANEL THICKNESS: 5.5MM

MATERIAL & FINISH

- ① CENTER CONTACT (JACK&PLUG): BRASS, GOLD PLATING
- ② BODY : ZINC ALLOY NICKEL PLATING
- ③ HOUSING : PBT (94 V-0)
- ④ INSULATOR : PE-606
- ⑤ MOUNTING POST : BRONZE, TIN PLATING
- ⑥ SOLDER TAIL : COPPER WIRE, TIN PLATING
- ⑦ WASHER : STEEL, NICKEL PLATING
- ⑧ NUT : BRASS, NICKEL PLATING



Phone 1-800-809-2751

Fax 1-510-440-0579

www.connect-tech-products.com • info@connect-tech-products.com

4428 Technology Drive • Fremont, CA 94538, USA • 510-498-8815 • Fax: 510-440-0579