

# CTP-BH-2005

Rev. B

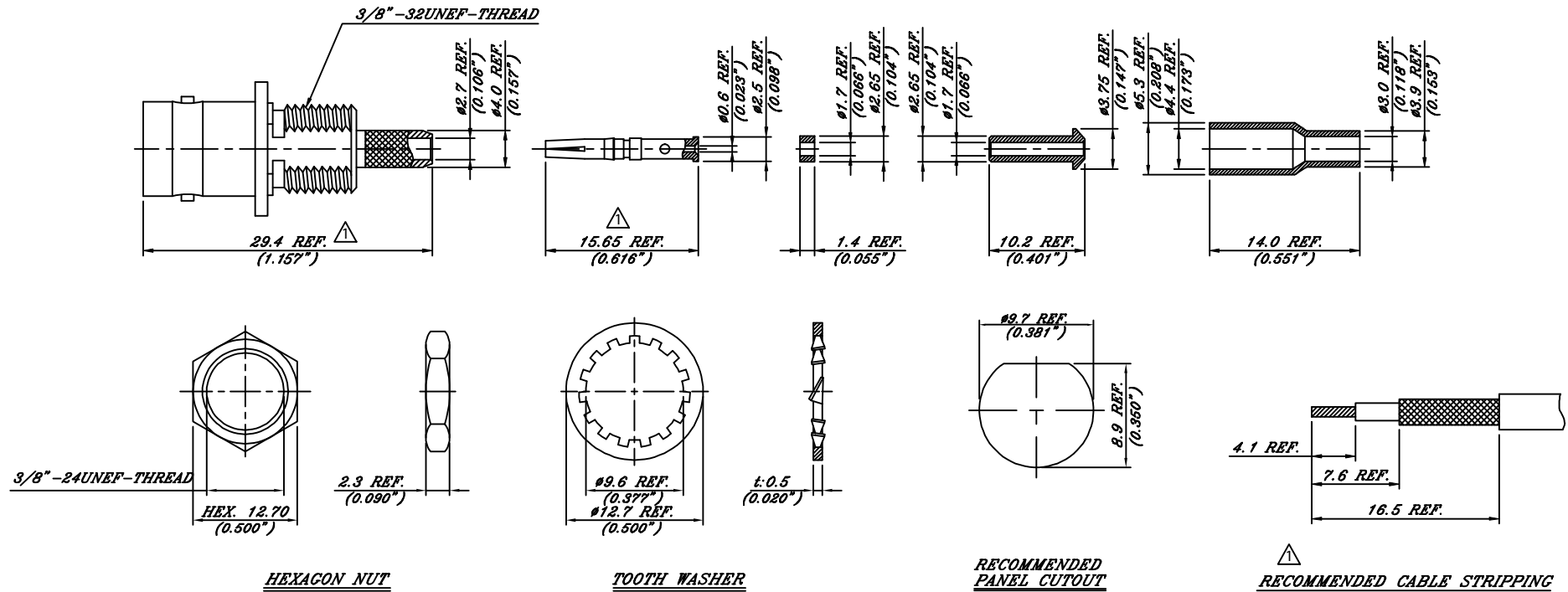

ITEM	DESCRIPTION	MATERIAL & TREATMENT	REMARK
1	CONNECTOR BODY	BRASS WITH NICKEL PLATING	
2	RETENTION WASHER	BRASS WITH NICKEL PLATING	
3	INSULATOR	TEFLON	
4	CENTER CONTACT	PHOSPHORUS BRONZE WITH GOLD PLATING	
5	INSULATION RING	TEFLON	
6	BUSH	BRASS WITH NICKEL PLATING	
7	CRIMPING SLEEVE	BRASS WITH NICKEL PLATING	
8	NUT	BRASS WITH NICKEL PLATING	
9	LOCK WASHER	BRASS WITH NICKEL PLATING	

RoHS COMPLIANT  
EU Directive 2002/95/EC

REV.	DESCRIPTION	DATE
△	CHANGE 29.7 TO 29.4	11/07/13
△	CHANGE 15.55 TO 15.65	11/07/13
△	CHANGE CABLE STRIPPED DIMENSION	11/07/13

**SPECIFICATIONS:**

**MECHANICAL CHARACTERISTICS:**  
MATING/UNMATING-500 CYCLES.

**ELECTRICAL CHARACTERISTICS:**  
NOMINAL IMPEDANCE-50 OHMS  
FREQUENCY RANGE- 0-1 GHz  
OPERATING VOLTAGE-500 VOLTS RMS  
CONTACT RESISTANCE-3.0 MILLIOHMS MAX.(GOLD)  
DIELECTRIC WITHSTANDING VOLTAGE-1500 VOLTS RMS.  
INSULATION RESISTANCE-5000 MEGOHMS MIN.

**ENVIRONMENTAL CHARACTERISTICS:**  
TEMPERATURE RANGE- -65°C TO +165°C  
THERMAL SHOCK-MIL-STD-202, METHOD 107, COND.B  
PHYSICAL SHOCK-MIL-STD-202, METHOD 204, COND.B

**DIMENSION:**

UNLESS OTHERWISE SPECIFIED ALL DIMENSIONS IN MILLIMETERS & INCHES. VALUES IN BRACKETS ARE INCHES EQUIVALENTS.



Phone 1-800-809-2751

Fax 1-510-440-0579

www.connect-tech-products.com • info@connect-tech-products.com

4428 Technology Drive • Fremont, CA 94538, USA • 510-498-8815 • Fax: 510-440-0579