

# CTP-BR-940 50 OHM

# CTP-7BR-940 75 OHM

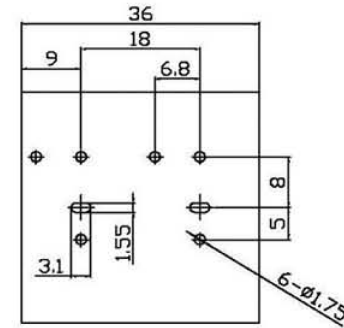
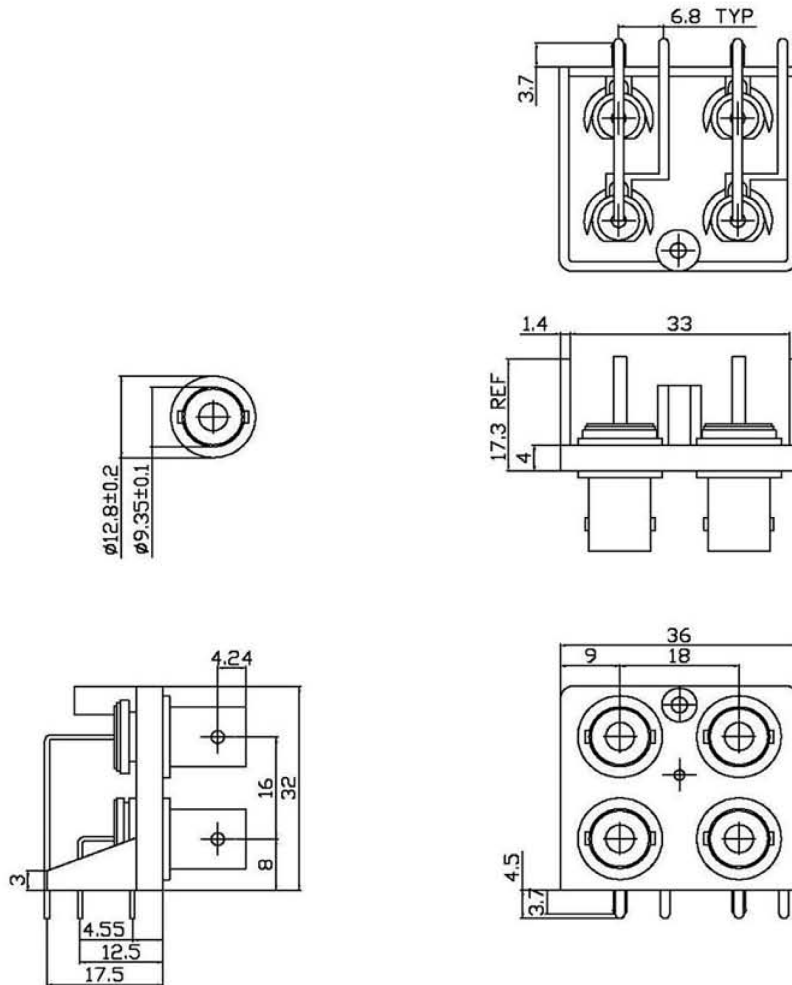

## MATERIALS:

1. Body: Zinc Alloy, Die Casting Nickel Plated.
2. Contact: Brass Nickel Plated.
3. Bracket: ABS
4. Insulator: Engineer Plastic POM

## OTHER INFORMATION:

1. Nominal Impedance: 50 (75) Ohm.
2. Frequency Range: 0-2 Ghz
3. Max Peak Voltage: 500V
4. Dielectric Strength withstand: 1.5KV NNS.
5. Insulation Resistance at 500 VDE 5000 Megohms Mal.

Phone 1-800-809-2751



Fax 1-510-440-0579

[www.connect-tech-products.com](http://www.connect-tech-products.com) • [info@connect-tech-products.com](mailto:info@connect-tech-products.com)

4428 Technology Drive • Fremont, CA 94538, USA • 510-498-8815 • Fax: 510-440-0579